

FEATURED MODEL

510-887R 8" & 10" bowl depths

ADDITIONAL MODELS

510-887 Left side large bowl, 10" & 8" bowl depths

510-888 Left side large bowl, 8" & 7" bowl depths

510-888R Right side large bowl, 7" & 8" bowl depths

FEATURES

- 18 gauge, 304 series stainless steel
- 18/10 chrome/nickel content
- Long-lasting, easy-to-clean, satin polished finish
- Rear drain placement

CODE/STANDARDS COMPLIANCE

ASME 112.19.3-00

IAPMO/UPC listed

OPTIONAL ACCESSORIES

Sink Grids: 510-901, 510-902

Colanders: 215-651, 510-889, 508-803

WARRANTY

Blanco America's Platinum Series sinks feature a "NO HASSLE" LIMITED LIFETIME WARRANTY to be free of all manufacturing defects under normal use. See our complete warranty for details.

While Blanco America endeavors to provide accurate information, all dimensions are nominal, cannot be guaranteed, and are subject to change or cancellation. Blanco America assumes no responsibility for use of superseded or voided specifications.

PRODUCT SPECIFICATION

Reverse bowl undermount sink to be 1-3/4 bowl design, 31-5/16" in length and 20-7/8" in front-to-back depth. Sink to be made from 18 gauge, 304 series stainless steel, with 18/10 chrome/nickel content and satin polished finish. Sink to feature rear drain placement. Sink to be Blanco Model 510-887R, with large bowl depth of 10" and small bowl depth of 8".



MODEL 510-887R

NOMINAL DIMENSIONS

MODEL	OVERALL	CUTOUT SIZE	BOWL DEPTH LEFT	BOWL DEPTH RIGHT	DRAIN DIAMETER
510-887R	31-5/16 x 20-7/8	Template provided with approximate 1/8" reveal	8	10	3-1/2

DXF cutout templates available on our web site or this specification CD.

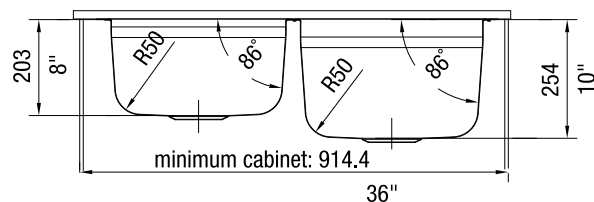
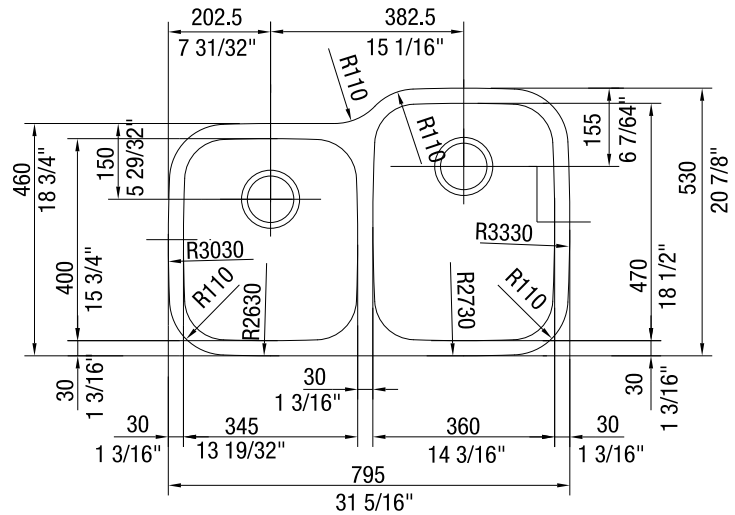

JOB INFORMATION

Job Name: _____

Contact: _____

Date Specified: _____

Specifier: _____

Contractor: _____